

# ELECTRIC FAN HEATER

## FAN HEATER FH series



- It can use as heating machine (assistance, spot) and drying machine.
- Fixing or all mounted
- It has adopted wide fan
- Time control : A fan drives after a stop for five minutes
- Temperature control : 0 ~ 40°C
- Burnout prevention setting : 100°C
- Paint color : 5Y7/1

### FAN HEATER (FH series) a list

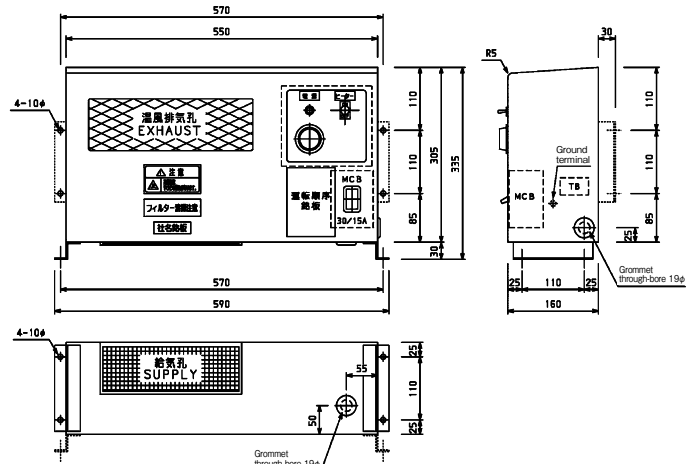
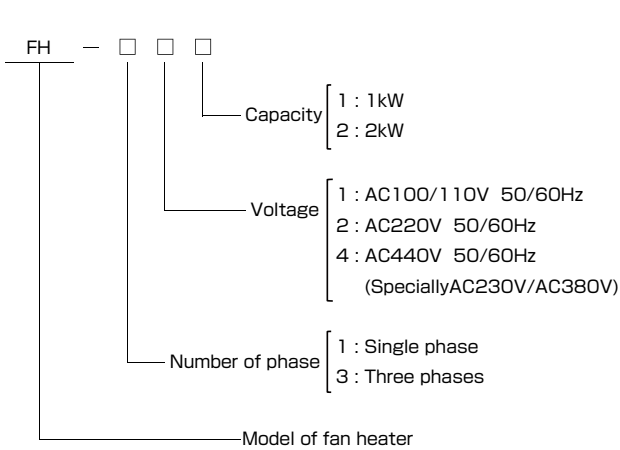

Model	Capacity	Voltage	Weight (kg)	Code No.
FH-111	1kW	AC100/110V 1φ	12	A27110001
FH-121	1kW	AC220V 1φ	12	A27110009
FH-321	1kW	AC220V 3φ	12	A27110013
FH-112	2kW	AC100/110V 1φ	13	A27110002
FH-122	2kW	AC220V 1φ	13	A27110003
FH-322	2kW	AC220V 3φ	13	A27110004
FH-342	2kW	AC230V 3φ	16	A271100053
FH-342	2kW	AC380V 3φ	16	A271100051
		AC440V 3φ		A27110005

### Circuit example of FH-322

