

ELECTRIC BUZZER

N.W.T. Electric Buzzer Type MZ

Item	Buzzer with Pilot lamp type push button switch				Buzzer with Pilot lamp		Buzzer with Push button switch				Buzzer	
Model	MZPL-F1	MZPL-F2	MZPL-S1	MZPL-S2	MZL-F2	MZL-S2	MZP-F1	MZP-F2	MZP-S1	MZP-S2	MZ-F2	MZ-S2
Mounting	Flush		Surface		Flush	Surface	Flush		Surface		Flush	Surface
Switch	1b contact Alternate	1b contact Momentary	1b contact Alternate	1b contact Momentary	—	—	1a contact Alternate	1a contact Momentary	1a contact Alternate	1a contact Momentary	—	—
Rated voltage / frequency	DC24V / AC110V 50/60Hz / AC220V 50/60Hz											
Sound pressure level	90dB(A)/over 1m											
Basic ambient temperature	45°C											
Vibration resistance	JIS F 8006 A1-B1. 0.5 class. 1.5H											
Protection degree	JIS F 8007 - IP20											
Insulation resistance	Between charge part and non charging metal Over 200Ω											
Voltage resistance	Between charge part and non charging metal DC24V:AC500V 1minute / AC110V, AC220V, AC1500V 1minute											
Color Box	Material color		Ivory white		Material color	Ivory white	Material color		Ivory white		Material color	Ivory white
Color Flush plate	Ivory white											
Weight	0.38kg		0.35kg		0.38kg	0.35kg	0.38kg		0.35kg		0.37kg	0.34kg
Code No.	4102100F1C	4102100F2C	4102100S1C	4102100S2C	4122100FC2-2	4122100SC2-2	4132100F1C	4132100F2C	4132100S1C	4132100S2C	4141100F2C-2	4141100S2C-2

With Push button switch

MZPL-F·MZP-F



MZPL-S·MZP-S



Flush mounting type (MZ-F2)

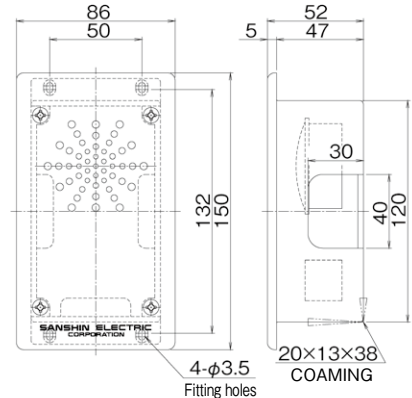

With Pilot lamp

MZL-F2



MZL-S2

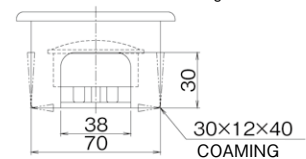

Surface mounting type (MZ-S2)

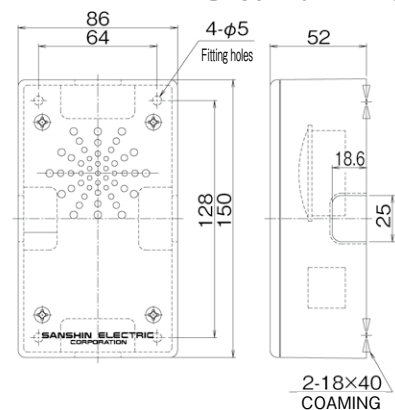

Buzzer only

MZ-F2



MZ-S2

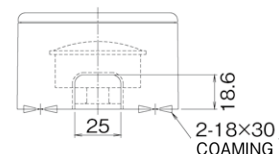

ELECTRIC BUZZER

W.T. Buzzer with Pilot lamp 2SLW

Model	2SLW		
Rated voltage	DC24V	AC100	AC220V
Gland	#20×1		
Material (Body)	Aluminum alloy		
Protection degree	IP44		
Weight	2.4kg		
Code No.	A08250056	A08250057	A08250058

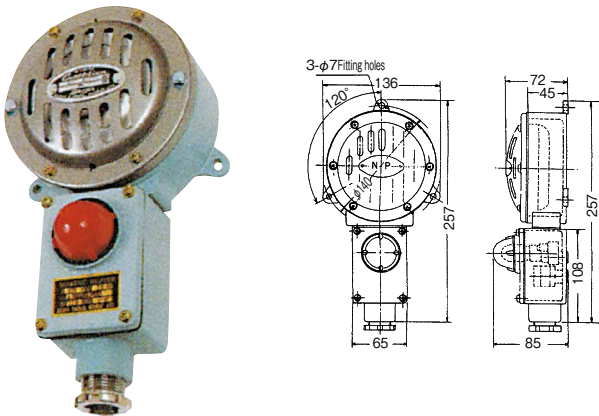

W.T. Buzzer 2SW

Model	2SW		
Rated voltage	DC24V	AC100	AC220V
Gland	#20×1		
Material (Body)	Aluminum alloy		
Protection degree	IP44		
Weight	1.7kg		
Code No.	A08250053	A08250054	A08250055

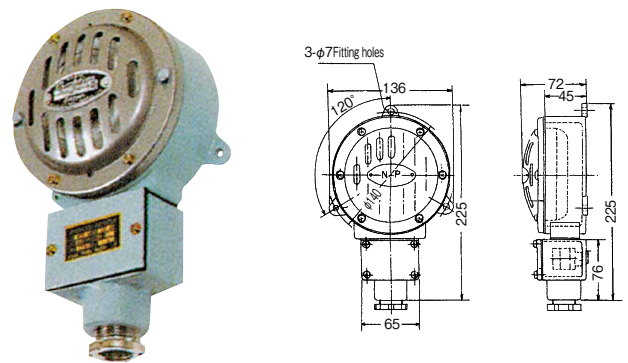

W.T. Horn buzzer with pilot lamp 3SLH

Model	3SLH		
Rated voltage	DC24V	AC100	AC220V
Gland	#20×1		
Material (Body)	Aluminum alloy		
Protection degree	IP44		
Weight	2.6kg		
Code No.	A08250203	A08250204	A08250205

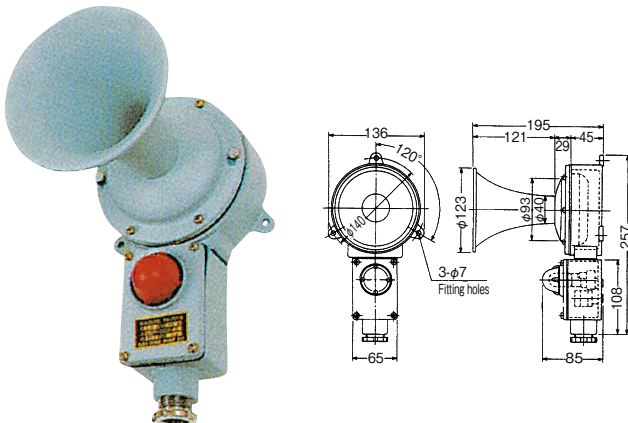

W.T. Horn buzzer 3SH

Model	3SH		
Rated voltage	DC24V	AC100	AC220V
Gland	#20×1		
Material (Body)	Aluminum alloy		
Protection degree	IP44		
Weight	1.9kg		
Code No.	A082502021	A082502024	A082502023

