

AIR TIGHT FLOOD LIGHT

FDL-24E

Air tight type flood light (Mercury lamp type)

- This product is a totally closed, highly airtight flood light developed mainly for ship cabin lighting.
- Its reflecting mirror, a well polished, specially coated aluminum sheet featuring high reflection efficiency and excellent resistance to corrosion, heat, chemicals and contamination is adopted, such that brightness lasts for a long time.
- The main materials for the lamp body, stainless steel and aluminum, which have excellent anti-corrosive properties, are adopted, with bake-coating performed after corrosion preventive treatment.

Installation	Horizontal
Elevation angle	Up 15° Down 45°
Turning angle	Left & right each 90°
Lamps	H400, HF400X
Standard temperature	45°C
Protection degree	IP66
Airtight ability	JIS F8442
Color	Munsell 7.5BG7/2
Weight	5.0kg
Code No.	1815E

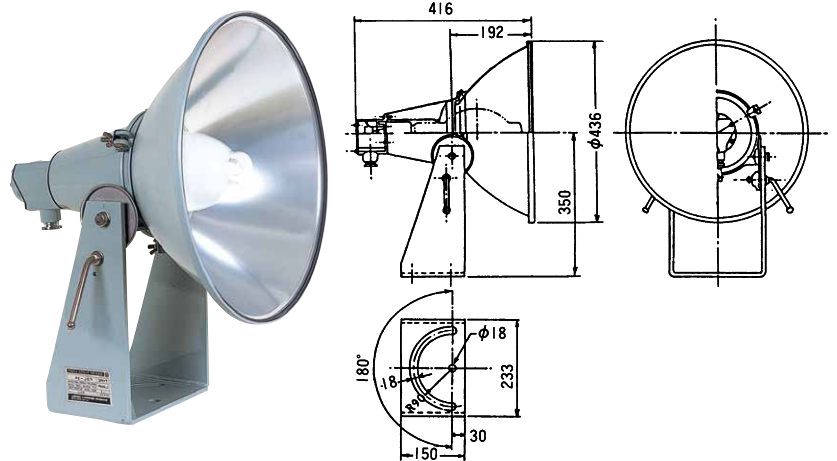

FDL-25E

Air tight type cargo light (Incandescent lamp type)

- This is an airtight cargo lamp satisfying the requirement of JISF8842 (Special cargo lamp) for lighting holds of coal transport ships.
- Its reflecting mirror, a well polished, specially coated aluminum sheet, featuring high reflection efficiency and with excellent resistance to corrosion, heat, chemicals and contamination is adopted.
- Its brightness lasts for a long time. To reduce the weight of the lighting fixture as a portable device, corrosion resistant aluminum alloy is adopted as the main material with bake-coating performed following corrosion preventive treatment.

Installation	Hanging
Source voltage	Less 250V
Lamps	500W, 300W
Standard temperature	45°C
Protection degree	IP66
Airtight ability	JIS F8442
Color	Munsell 7.5BG7/2
Weight	5.6kg
Code No.	1829-1

